

## OPERATION (FIGURE 4)

The GH-Series Gimbal Heads are professional devices and once adjusted for typical operation only require two controls. Slightly loosen both the Tilt Knob and Pan Knob. Then aim the camera at the subject and tighten both Knobs to lock.

If you're photographing and following action, you may keep both Knobs loose and take advantage of the stability offered by the Gimbal Head. **Lock the Knobs when you are finished or are not firmly holding the Camera/Lens.**

**FOR OPTIMUM RESULTS:** Adjust the balance and Camera/Lens positioning with the weight capacity, temperature and conditions under which the Gimbal Head will be used.

**NOTE:** Do not over tighten any Locking Knobs or try to move the Camera/Lens once tightened as this could damage the Gimbal Head locking mechanism.

## USER NOTICE

- ① Do not exceed the maximum specified load capacity (see specifications on the package label or visit [www.Induro.com](http://www.Induro.com)).
- ① Always ensure that all Ballhead locks are tightly engaged before mounting any gear.
- ① Do not use any Ballhead below temperatures of  $-4^{\circ}\text{F}$  or above  $+158^{\circ}\text{F}$  ( $-20^{\circ}\text{C}$  /  $+70^{\circ}\text{C}$ ).
- ① Always clean and dry any Ballhead after it has been exposed to wet, dusty, sandy or salty conditions. Your Ballhead is not recommended for use in salt water. If required, clean Ballhead using a mild soap solution applied with a soft cloth, rinse with fresh water and dry with soft towel. Remove any dust, dirt or sand from all locks and all moving parts.
- ① Do not leave any Ballhead in the sun for prolonged periods and avoid high temperature exposure.
- ① Avoid leaving any Tripod or Monopod unattended in areas where people could trip over the gear and get hurt.
- ① Remove camera, lens, and all gear from any Tripod or Monopod when transporting.
- ① For your safety, don't let your Induro gear come in contact with any electrical power source.

**INDURO™**

INDURO Camera Support Gear | 8 Westchester Plaza, Elmsford, NY 10523 | T 914-347-3300 | F 914-347-3309 | info@indurogear.com | indurogear.com

# INDURO™

## GH-SERIES GIMBAL HEAD OPERATING INSTRUCTIONS

Thank you for making Induro your choice for professional photographic gear. Your Induro gear is manufactured to provide years of dependable service. In order to obtain optimum satisfaction and performance we suggest that you carefully read these instructions and provide them to anyone who may also use your Induro gear.

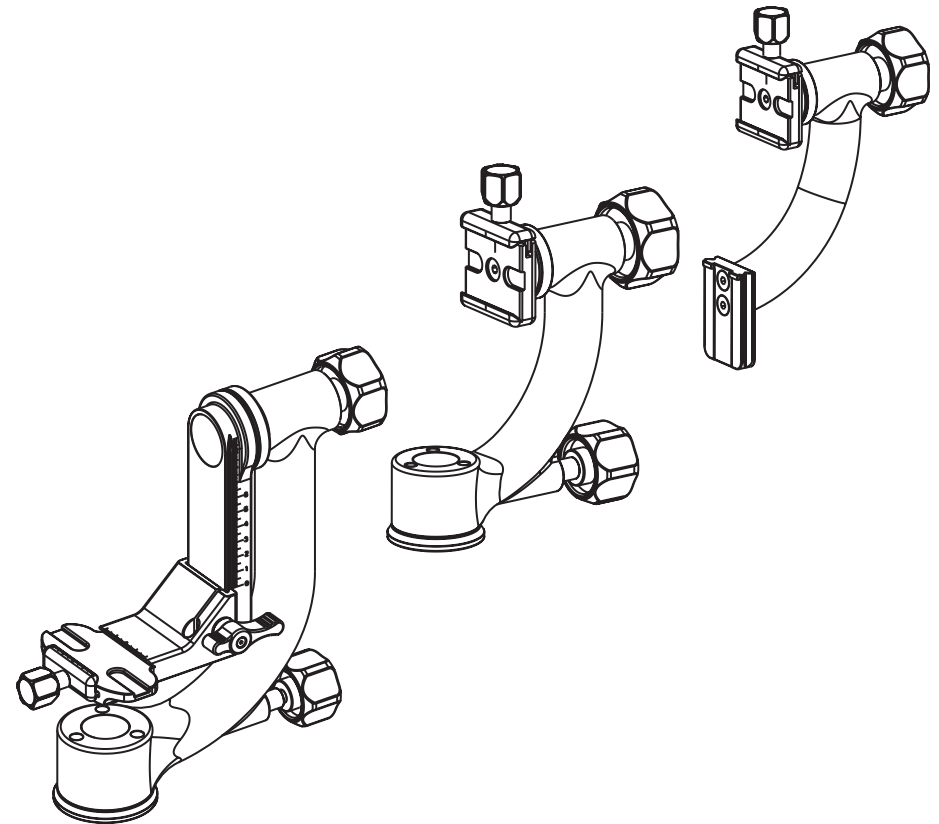

Specifications and design are subject to change without notice.

All tradenames, logos, and brand references are the respective trademarks of their owners.

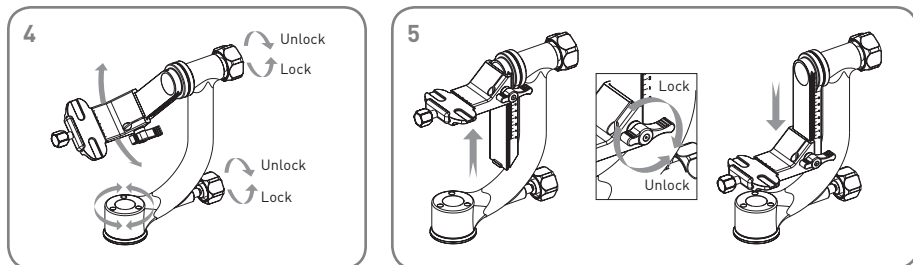
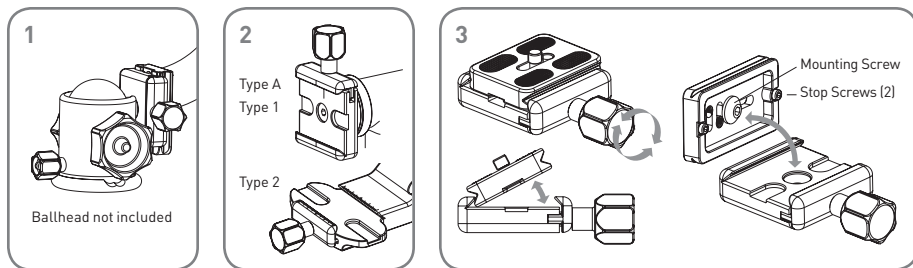
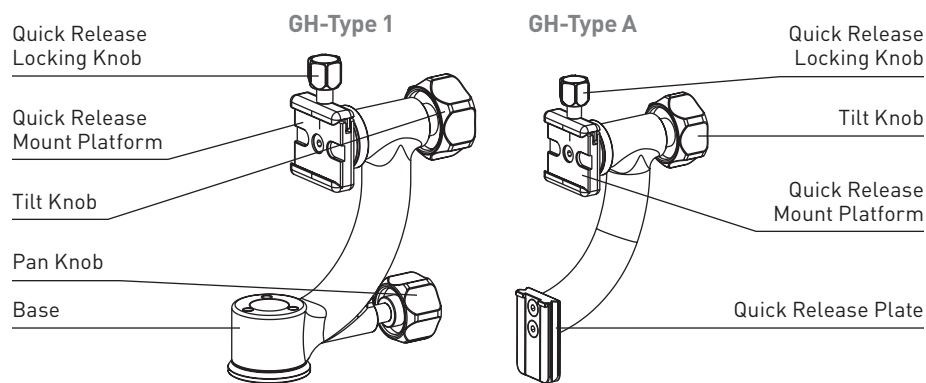
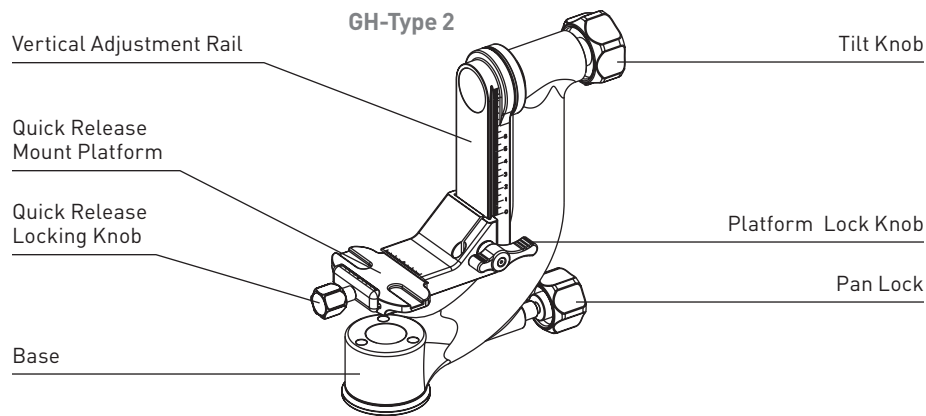

**INTRODUCTION**

Your Induro GH-Series Gimbal Head is a precision device which, when properly setup allows almost effortless pan and tilt movements of most Camera/Lens systems. These instructions cover the proper setup and operation of three different Types of Gimbal Heads and should be read completely prior to mounting and operating your Gimbal Head.

**SETUP**

**Head Mounting (FIGURE 1)**

**TYPE A:** Fit the Quick Release plate onto the Universal Arca-Swiss style Quick Release Clamp of a Ball Head rated for heavy duty operation. Select an Induro model or other high quality brand that incorporates a secondary Safety Lock System.

**TYPE 1:** Install by screwing the head clockwise onto the 3/8" mounting thread of the top plate of the Tripod. Once the Base is hand tight, if available, secure by fully tightening the Head Locking Screw(s) from below with the included Allen Key.

**TYPE 2:** The camera Quick Release Mount Platform must first be attached to the Vertical Adjustment Rail by loosening the Platform Lock Knob and sliding the Platform down to the bottom of the Rail. Tighten the Lock Knob. You will be able to adjust position later after the camera is mounted. Follow the Type 1 instructions above to attach the Gimbal Head to your Tripod.

**Universal Quick Release Plate System**

The GH-Series Gimbal Heads feature a Universal Arca-Swiss style Quick Release Plate system. It offers a quick method of mounting or releasing a Camera or Equipment from the Head. It's important that the correct Quick Release Plate be used along with the proper mounting screw (1/4-20 is included as the standard size but spare 1/4-20 and 3/8 plates of various lengths are available as accessories). The Mounting Screw requires an Allen Key which is included. Extra Plates are recommended as you can screw one to each Camera or Lens for even greater convenience when rapidly mounting and dismounting gear. And because of compatibility with the Universal Arca-Swiss style system, most plates and special brackets from other manufacturers can be used as well.

**Quick Release Mount Platform (FIGURE 2)**

All three Gimbal Head models feature a center line on the Quick Release Mount Platform for reference positioning of the Quick Release Plate. In addition, the longer Type 2 Quick Release Platform allows for greater flexibility in providing camera balance, and includes full scale index marks for more precise repositioning.

**Quick Release Lock (FIGURE 3)**

When used properly, the Quick Release Lock offers two levels of security for your gear. To remove the Quick Release Plate, **firmly hold the Camera/Lens** and turn the Quick Release Locking Knob counter-clockwise. A partial opening of the clamping mechanism allows the Quick Release Plate to slide on the Mounting Platform for proper balance and positioning. Two Stop Screws (removable) on the bottom of the Quick Release Plate provide this first level of security. An additional counter-clockwise turn of the Quick Release Locking Knob opens the clamp fully so that the Quick Release Plate can be tilted out to be removed. Reverse the process once again **firmly holding the Camera/Lens** and tighten the Quick Release Locking Knob to secure the Quick Release Plate.

**Gimbal Head Tilt Control (FIGURE 4)**

When fully adjusted, the lateral positioning of a Camera/Lens on a Gimbal Head should allow neutral balance which means that most front and rear tilt movements will stay fixed even with the Tilt Knob unlocked. Best positioning may require the purchase of an accessory extra-long plate. Type 2 Gimbal Heads offer the additional feature of an indexed vertical adjustment to permit better alignment of the Lens Axis with the Tilt Axis.

**Setting System Balance (FIGURES 4 & 5)**

While **holding the Camera/Lens**, rotate the Tilt Knob counter-clockwise to loosen the Tilt Pivot. Allow the Arm to swing gently to determine whether the natural movement of the weighted mechanism is to tilt up or down. If the lens is tilting down then while still **holding the Camera/Lens** partially loosen the Quick Release Locking Knob and slide the mounted Camera/Lens to the rear until neutral balance is achieved. Turn the Quick Release Locking Knob clockwise to secure.

Type 2 Gimbal Heads offer the same setting for balance, however this adjustment should be made after the Lens Axis is positioned approximately in-line with the Gimbal Tilt Axis. The vertical adjustment can be accomplished by turning the Platform Lock Knob counter-clockwise and sliding the entire Platform up to position. Once you have found the neutral balance point tighten the Platform Lock Knob clockwise to secure.